

Section 6 – Interoperability

6.1 Introduction

The ability of agencies to effectively respond to mutual aid requests directly depends on their ability to communicate with each other. Washington State is subject to natural disasters such as the geological activity at Mount St. Helens, the Nisqually Earthquake, and wild land fires, and mutual aid is common among agencies. This plan seeks to facilitate the communications necessary for effective mutual aid.

Washington State will administer the Interoperability (I/O) channels via its State Interoperability Executive Committee (SIEC) under National Coordination Committee's (NCC) guidelines. In addition to the role described within this document, Washington's SIEC will be pursuing other activities relating to Interoperability outside of the 700 MHz spectrum, including assisting in the coordination of interoperability spectrum resources at VHF, UHF and 800 MHz.

Washington State adopts the ANSI/TIA 102 Standards, i.e. Project 25 digital protocols, as the Digital Interoperability Standard for the conventional-only mode of operation on the narrowband voice & data interoperability channels as adopted by the NCC and shown in Appendix A.

There are 2 Calling channel sets and 30 Tactical channel sets. Channel sets are comprised of two 6.25 kHz channels each.

The Tactical channel sets are subdivided into the following categories for Washington State:

- 2 — for Emergency Medical Services
- 2 — for Fire Services
- 2 — for joint Fire and Emergency Medical Services
- 4 — for Law Enforcement Services
- 2 — for Mobile Repeater operation
- 2 — for Other Public Services
- 12 — for General Services, and
- 2 — for Data

While defined as intended for specific operational needs, the Tactical channel sets may be assigned for alternate uses by the Incident Commander. As an example, the Incident Commander may find that a fire channel is the only Tactical channel resource constructed in an area where an EMS response is called for. Under these circumstances, functional reassignment of the channel may be made on a coordinated basis for the duration of the incident under direction of the Incident Commander.

6.2 Calling Channels

Washington State operates two Calling channel sets. The Calling channels set designations within Washington State are "CALL 7A" and "CALL 7B" "7CAL59" and "7CAL75". These calling channel sets shall be monitored, on a 24 x 7 basis, by licensees who employ 700 MHz channels from the general use or state pool as a part of their infrastructure. When calling channels are integrated into infrastructure, their mobile coverage must at least match the coverage of the other channels in the system. In addition to the usual calling channel functions, the calling channels may be used to notify users when a priority is declared on one or more of the tactical interoperability channels.

6.3 Requirement for Infrastructure to Support Interoperability Channels¹

All agencies requesting General Use spectrum from this Plan will be required to implement the number of Interoperability channels designated in the table in Footnote 1. This implementation shall normally provide mobile area coverage over essentially the same service area as the primary communications channel assignments. The SIEC, or its designee, may authorize reduced coverage, reduced channel count, or extended/delayed implementation where such a reduction is required to meet good engineering standards, interference mitigation or other specialized requirements. This infrastructure may be configured to operate in a half duplex mode to minimize intra-system interference under routine conditions, provided however that a wireline equivalent connection delivers received audio to a dispatch point where 24 x 7 monitoring will take place. Approval of such operation also requires the ability for the dispatch point to re-enable normal repeater operation when so requested.

Agencies are encouraged to provide for additional interoperability channels and improved grades of service beyond the requirements establish in this Section.

6.4 Tactical Channels

¹ Required Interoperability Channels based on total licensed bandwidth

Bandwidth Licensed	Required Number of Interoperability Channels
0 to 50 kHz	None
62.5 to 100 kHz	1 Call Channel
112.5 to 175 kHz	1 Call Channel 1 Law Enforcement Channel 1 Fire/EMS Channel
> 175 kHz	1 Call Channel 1 Law Enforcement Channel 1 Fire Channel 1 EMS Channel

All Interoperability channels, except as described below, shall be used for conventional-only operation. Normally, users will 'call' a dispatch center on one of the "Calling Channels" and be assigned an available tactical channel. Deployable narrowband operations (voice, data, and trunking) shall be afforded access to the same pool of channels used for similar fixed infrastructure operations. In the event of conflict between multiple activities, prioritized use shall occur. Use prioritization shall be:

- 1 Disaster and extreme emergency operations for mutual aid and interagency communications.
- 2 Emergency or urgent operation involving imminent danger to life or property.
- 3 Special event control, generally of a preplanned nature (including Task Force operations).

6.5 Encryption

Use of encryption is prohibited on Calling channels and permitted on all other interoperability channels. A standardized encryption algorithm for use on the interoperability channels must adhere to ~~TIA/EIA IS AAAAA Project 25 DES encryption protocol~~ FCC Part 90 Rules.

6.6 Deployable Systems

Washington State supports the use of deployable systems, both conventional and trunked. Deployable systems are prepackaged systems that can deploy by ground or air to an incident to provide additional coverage and capacity on interoperability channels. This strategy minimizes the expense of installing fixed infrastructure and recognizes the difficulty of providing complete coverage to Washington State due to environmental constraints.

General Public Safety Service Channels labeled ~~GTAC 21 and GTAC 31, GTAC 51 and GTAC 61, or both,~~ "7MOB72" and "7MOB88" shall be made available for "deployable" equipment used during disasters and other emergency events that place a heavy, unplanned burden upon in-place radio systems. Use of deployable conventional and trunked interoperability systems will be coordinated so as to minimize interference with permanently installed conventional interoperability infrastructure.

6.7 Trunking on the Interoperability Channels

Trunking the Interoperability channels for deployable or inactive, pre-positioned systems shall be permitted on a secondary basis to fixed conventional infrastructure. Such use shall be limited to operation on eight specific 12.5 kHz channel sets, divided into two subsets of four 12.5 kHz channels. Trunked operation on the Interoperability channels is intended to provide for heavy communications needs at specific locations

and these channels are not intended to be used in the trunked mode for permanent operations. In future revisions to this Plan, the Washington state SIEC anticipates developing additional plans which anticipate talkgroup structures, enabling the use of the interoperability spectrum for deployable or inactive, pre-positioned systems.

6.8 Standard Operating Procedures on the Trunked I/O Channels For I/O Situations Above Level 4

The safety and security of life and property determines appropriate interoperable priorities of access and/or reverting from secondary trunked to conventional operation. Access priority for "mission critical" communications is recommended as follows:

1. Disaster and extreme emergency operations for mutual aid and interagency communications;
2. Emergency or urgent operation involving imminent danger to life or property;
3. Special event control, generally of a preplanned nature (including Task Force operations)

The SIEC will determine whether a wide-area I/O conversation has priority over a local I/O conversation.

6.9 Data Only Use of the I/O Channels

Narrowband data-only interoperability operation on the Interoperability channels on a secondary basis shall be limited to two specific 12.5 kHz channel sets. One set is defined by GTAC 21 and the other by GTAC 51, named "7DAT71" and 7DAT87".

6.10 Wideband Data Standards Channels

Within the 12 MHz of spectrum designated for high capacity, wide bandwidth (50 to 150 kHz) channel usage, there are eighteen 50 kHz (or six 150 kHz) channels designated for wideband interoperability use.

6.11 State Interoperability Executive Committee

Washington State will use the Incident Command System National Incident Management System (NIMS) as a guideline in developing their regional interoperability plans.

Washington State will have oversight of the administration and technical parameters of the infrastructure for the interoperability channels within the state, unless such oversight is formally delegated by the SIEC to some other body, such as the RPC.

6.12 Minimum Channel Quantity

The minimum channel quantity for Calling and tactical channel sets requires 8 I/O channel slots in each subscriber unit. Including Direct (simplex) mode on these channel sets, up to 16 slots in each radio will be programmed for I/O purposes. Backbone issues will be deferred to the SIEC. Subscriber units, which routinely roam through more than one jurisdiction up to nationwide travel will require more than the minimum channel quantity.

The "CALL"ing channel sets (CALL 7A and CALL 7B) shall be implemented in all voice subscriber units in repeat mode and direct (simplex) mode. "Direct" mode is permitted in the absence of repeat operation or upon prior dispatch center coordination. If the local CALLing channel set is not known, CALL 7A shall be attempted first, then CALL 7B. Attempts shall be made on the repeater mode first then on the direct (simplex) mode. A minimum set of "TAC"tical channels shall be implemented in every voice subscriber unit in the direct (simplex) mode. Specific channel sets are shown below.

OTAC33 and OTAC63 channel sets
MTAC23 & 5MTAC3 channel sets
GTAC31 & 61channel sets

NOTE: Selection of the above TAC channels based on revised Table of Interoperability Channels. Channel labels are a compromise between 4th R&O and IO 0062D 20010118.

Voice subscriber units subject to multi-jurisdictional or nationwide roaming should have all I/O voice channels, including direct (simplex) mode, programmed for use.

The minimum channel quantity for Calling and tactical channel sets are detailed in Appendix A, which is the arrangement proposed in the final report of the NCC to the FCC in July 2003. Backbone issues will be deferred to the SIEC.

6.13 Direct (Simplex) Mode

In direct (simplex) mode, transmitting and receiving on the output (transmit) side of the repeater pair for subscriber unit-to-subscriber unit communications at the scene does not congest the repeater station with unnecessary traffic. However, should someone need the repeater to communicate with the party who is in "direct" mode, the party would hear the repeated message, switch back to the repeater channel, and join the communications. Therefore, operating in direct (simplex) mode shall only be permitted on the repeater output side of the voice I/O channel sets.

6.14 Common Channel Access Parameters

Common channel access parameters will provide uniform I/O communications regardless of jurisdiction, system, manufacturer, etc. This national requirement should apply to base stations and subscriber units. This should apply to fixed or temporary operations. This should apply to tactical, voice, or other mutual aid conventional I/O use.

Common channel access parameters for all voice I/O shall utilize the default values (ANSI/TIA/EIA-102, BAAC-2000, approved April 25, 2000) provided in every radio regardless of manufacturer. Any common channel access parameters not provided shall be programmed accordingly. These parameters include the following:

- P25 Network Access Code - \$293 (default value)
- P25 Manufacturers ID - \$00 (default value)
- P25 Designation ID - \$FFFFFF (designates everyone)
- P25 Talkgroup ID - \$0001 (default value)
- P25 Message Indicator \$000000... 0, out to 24 zeros (unencrypted)
- P25 Key ID - \$0000 (default value)
- P25 Algorithm ID - \$80 (unencrypted)

Any deviation from \$293 will not be permitted unless the SIEC (or the RPC) can demonstrate Plan amendment through the FCC-approved process that the intent of \$293 will be preserved on ALL conventional voice I/O channels – transmit and receive.

The following table is also recommended for insertion in the Plan as Appendix A. This will make the Region 43 Plan match the final recommendations by the NCC.



D:\My Documents\
Region 43 NPSPAC ar

700 MHz Interoperability Channels, Labels, and Usage

	12.5 kHz CHANNEL PAIR	CHANNEL LABEL (proposed)	RADIO SERVICE	TALK-AROUND	CHANNEL LABEL (proposed)	USE/MISC NOTES
01	Pair 23-24/983-984	7TAC58	General Public Safety Service (secondary trunked)	Channel 23-24	7TAC58D	
02	Pair 39-40/999-1000	7CAL59	Calling Channel	Channel 39-40	7CAL59D	mandatory
03	Pair 63-64/1023-1024	7EMS60	EMS	Channel 63-64	7EMS60D	
04	Pair 79-80/1039-1040	7EMS61	EMS	Channel 79-80	7EMS61D	
05	Pair 103-104/1063-1064	7TAC62	General Public Safety Service (secondary trunked)	Channel 103-104	7TAC62D	
06	Pair 119-120/1079-1080	7TAC63	General Public Safety Service	Channel 119-120	7TAC63D	mandatory
07	Pair 143-144/1103-1104	7FIR64	Fire	Channel 143-144	7FIR64D	
08	Pair 159-160/1119-1120	7FIR65	Fire	Channel 159-160	7FIR65D	
09	Pair 183-184/1143-1144	7TAC66	General Public Safety Service (secondary trunked)	Channel 183-184	7TAC66D	
10	Pair 199-200/1159-1160	7TAC67	General Public Safety Service	Channel 199-200	7TAC67D	
11	Pair 223-224/1183-1184	7LAW68	Police	Channel 223-224	7LAW68D	
12	Pair 239-240/1199-1200	7LAW69	Police	Channel 239-240	7LAW69D	
13	Pair 263-264/1223-1224	7TAC70	General Public Safety Service (secondary trunked)	Channel 263-264	7TAC70D	
14	Pair 279-280/1239-1240	7DAT71	Mobile Data	Channel 279-280	7DAT71D	
15	Pair 303-304/1263-1264	7MOB72	Mobile Repeater	Channel 303-304	7MOB72D	mandatory
16	Pair 319-320/1279-1280	7TAC73	Other Public Service	Channel 319-320	7TAC73D	mandatory

Channels labeled as mandatory include both the mobile transmit and mobile receive (a total of 16 channels) for subscriber units only

700 MHz Interoperability Channels, Labels, and Usage (continued)

	12.5 kHz CHANNEL PAIR	CHANNEL LABEL	RADIO SERVICE	TALK-AROUND	CHANNEL LABEL	USE/MISC NOTES
17	Pair 641-642/1601-1602	7EMS76	EMS	Channel 641-642	7EMS76D	
18	Pair 657-658/1617-1618	7TAC74	General Public Safety Service (secondary trunked)	Channel 657-658	7TAC74D	
19	Pair 681-682/1641-1642	7CAL75	Calling Channel	Channel 681-682	7CAL75D	mandatory
20	Pair 697-698/1657-1658	7EMS77	EMS	Channel 697-698	7EMS77D	
21	Pair 721-722/1681-1682	7FIR80	Fire	Channel 721-722	7FIR80D	
22	Pair 737-738/1697-1698	7TAC78	General Public Safety Service (secondary trunked)	Channel 737-738	7TAC78D	
23	Pair 761-762/1721-1722	7TAC79	General Public Safety Service	Channel 761-762	7TAC79D	mandatory
24	Pair 777-778/1737-1738	7FIR81	Fire	Channel 777-778	7FIR81D	
25	Pair 801-802/1761-1762	7LAW84	Police	Channel 801-802	7LAW84D	
26	Pair 817-818/1777-1778	7TAC82	General Public Safety Service (secondary trunked)	Channel 817-818	7TAC82D	
27	Pair 841-842/1801-1802	7TAC83	General Public Safety Service	Channel 841-842	7TAC83D	
28	Pair 857-858/1817-1818	7LAW85	Police	Channel 857-858	7LAW85D	
29	Pair 881-882/1841-1842	7MOB88	Mobile Repeater	Channel 881-882	7MOB88D	mandatory
30	Pair 897-898/1857-1858	7TAC86	General Public Safety Service (secondary trunked)	Channel 897-898	7TAC86D	
31	Pair 921-922/1881-1882	7DAT87	Mobile Data	Channel 921-922	7DAT87D	
32	Pair 937-938/1897-1898	7TAC89	Other Public Service	Channel 937-938	7TAC89D	mandatory

Channels labeled as mandatory include both the mobile transmit and mobile receive (a total of 16 channels) for subscriber units only

700 MHz Interoperability Channels – Frequency List

	FREQUENCY (MHz) OR CHANNEL SET Channel Pair	CHANNEL LABEL (proposed)	USE/MISC NOTES	FREQUENCY (lower edge) (base) (mobile)		FREQUENCY (center) (base) (mobile)	
01	Pair 23-24/983-984	7TAC58		764.13750	794.13750	764.14375	794.14375
02	Pair 39-40/999-1000	7CAL59	mandatory	764.23750	794.23750	764.24375	794.24375
03	Pair 63-64/1023-1024	7EMS60		764.38750	794.38750	764.39375	794.39375
04	Pair 79-80/1039-1040	7EMS61		764.48750	794.48750	764.49375	794.49375
05	Pair 103-104/1063-1064	7TAC62		764.63750	794.63750	764.64375	794.64375
06	Pair 119-120/1079-1080	7TAC63	nationwide	764.73750	794.73750	764.74375	794.74375
07	Pair 143-144/1103-1104	7FIR64		764.88750	794.88750	764.89375	794.89375
08	Pair 159-160/1119-1120	7FIR65		764.98750	794.98750	764.99375	794.99375
09	Pair 183-184/1143-1144	7TAC66		765.13750	795.13750	765.14375	795.14375
10	Pair 199-200/1159-1160	7TAC67	(alt)	765.23750	795.23750	765.24375	795.24375
11	Pair 223-224/1183-1184	7LAW68		765.38750	795.38750	765.39375	795.39375
12	Pair 239-240/1199-1200	7LAW69		765.48750	795.48750	765.49375	795.49375
13	Pair 263-264/1223-1224	7TAC70		765.63750	795.63750	765.64375	795.64375
14	Pair 279-280/1239-1240	7DAT71		765.73750	795.73750	765.74375	795.74375
15	Pair 303-304/1263-1264	7MOB72	nationwide	765.88750	795.88750	765.89375	795.89375
16	Pair 319-320/1279-1280	7TAC73	nationwide	765.98750	795.98750	765.99375	795.99375

700 MHz Interoperability Channels – Frequency List (continued)

FREQUENCY (MHz) OR CHANNEL SET Channel Pair	CHANNEL LABEL (proposed)	USE/MISC NOTES	FREQUENCY (lower edge)		FREQUENCY (center)	
			(base)	(mobile)	(base)	(mobile)
17 Pair 641-642/1601-1602	7EMS76		774.00000	804.00000	774.00625	804.00625
18 Pair 657-658/1617-1618	7TAC74		774.10000	804.10000	774.10625	804.10625
19 Pair 681-682/1641-1642	7CAL75	mandatory	774.25000	804.25000	774.25625	804.25625
20 Pair 697-698/1657-1658	7EMS77		774.35000	804.35000	774.35625	804.35625
21 Pair 721-722/1681-1682	7FIR80		774.50000	804.50000	774.50625	804.50625
22 Pair 737-738/1697-1698	7TAC78		774.60000	804.60000	774.60625	804.60625
23 Pair 761-762/1721-1722	7TAC79	nationwide	774.75000	804.75000	774.75625	804.75625
24 Pair 777-778/1737-1738	7FIR81		774.85000	804.85000	774.85625	804.85625
25 Pair 801-802/1761-1762	7LAW84		775.00000	805.00000	775.00625	805.00625
26 Pair 817-818/1777-1778	7TAC82		775.10000	805.10000	775.10625	805.10625
27 Pair 841-842/1801-1802	7TAC83	(alt)	775.25000	805.25000	775.25625	805.25625
28 Pair 857-858/1817-1818	7LAW85		775.35000	805.35000	775.35625	805.35625
29 Pair 881-882/1841-1842	7MOB88	nationwide	775.50000	805.50000	775.50625	805.50625
30 Pair 897-898/1857-1858	7TAC86		775.60000	805.60000	775.60625	805.60625
31 Pair 921-922/1881-1882	7DAT87		775.75000	805.75000	775.75625	805.75625
32 Pair 937-938/1897-1898	7TAC89	nationwide	775.85000	805.85000	775.85625	805.85625

700 MHz Interoperability Channels – Talk-around (Simplex/Direct) Frequency List

	TALK-AROUND	CHANNEL LABEL (proposed)	FREQUENCY (lower edge) (base) (mobile)		FREQUENCY (center) (base) (mobile)	
01	Channel 23-24	7TAC58D	764.13750	794.13750	764.14375	794.14375
02	Channel 39-40	7CAL59D	764.23750	794.23750	764.24375	794.24375
03	Channel 63-64	7EMS60D	764.38750	794.38750	764.39375	794.39375
04	Channel 79-80	7EMS61D	764.48750	794.48750	764.49375	794.49375
05	Channel 103-104	7TAC62D	764.63750	794.63750	764.64375	794.64375
06	Channel 119-120	7TAC63D	764.73750	794.73750	764.74375	794.74375
07	Channel 143-144	7FIR64D	764.88750	794.88750	764.89375	794.89375
08	Channel 159-160	7FIR65D	764.98750	794.98750	764.99375	794.99375
09	Channel 183-184	7TAC66D	765.13750	795.13750	765.14375	795.14375
10	Channel 199-200	7TAC67D	765.23750	795.23750	765.24375	795.24375
11	Channel 223-224	7LAW68D	765.38750	795.38750	765.39375	795.39375
12	Channel 239-240	7LAW69D	765.48750	795.48750	765.49375	795.49375
13	Channel 263-264	7TAC70D	765.63750	795.63750	765.64375	795.64375
14	Channel 279-280	7DAT71D	765.73750	795.73750	765.74375	795.74375
15	Channel 303-304	7MOB72D	765.88750	795.88750	765.89375	795.89375
16	Channel 319-320	7TAC73D	765.98750	795.98750	765.99375	795.99375

700 MHz Interoperability Channels – Talk-around (Simplex/Direct) Frequency List (continued)

	TALK-AROUND	CHANNEL LABEL (proposed)	FREQUENCY (lower edge) (base) (mobile)	FREQUENCY (center) (base) (mobile)
17	Channel 641-642	7EMS76D	774.00000 804.00000	774.00625 804.00625
18	Channel 657-658	7TAC74D	774.10000 804.10000	774.10625 804.10625
19	Channel 681-682	7CAL75D	774.25000 804.25000	774.25625 804.25625
20	Channel 697-698	7EMS77D	774.35000 804.35000	774.35625 804.35625
21	Channel 721-722	7FIR80D	774.50000 804.50000	774.50625 804.50625
22	Channel 737-738	7TAC78D	774.60000 804.60000	774.60625 804.60625
23	Channel 761-762	7TAC79D	774.75000 804.75000	774.75625 804.75625
24	Channel 777-778	7FIR81D	774.85000 804.85000	774.85625 804.85625
25	Channel 801-802	7LAW84D	775.00000 805.00000	775.00625 805.00625
26	Channel 817-818	7TAC82D	775.10000 805.10000	775.10625 805.10625
27	Channel 841-842	7TAC83D	775.25000 805.25000	775.25625 805.25625
28	Channel 857-858	7LAW85D	775.35000 805.35000	775.35625 805.35625
29	Channel 881-882	7MOB88D	775.50000 805.50000	775.50625 805.50625
30	Channel 897-898	7TAC86D	775.60000 805.60000	775.60625 805.60625
31	Channel 921-922	7DAT87D	775.75000 805.75000	775.75625 805.75625
32	Channel 937-938	7TAC89D	775.85000 805.85000	775.85625 805.85625

700 MHz Narrowband Channel Layout Plan – TV Channel 63-68 (764-767/794-797 MHz)

TV CH 63/68

441	401	361	321	281	241	201	161	121	81	41	1	0 kHz
442	402	362	322	282	242	202	162	122	82	42	2	
443	403	363	323	283	243	203	163	123	83	43	3	
444	404	364	324	284	244	204	164	124	84	44	4	
445	405	365	325	285	245	205	165	125	85	45	5	
446	406	366	326	286	246	206	166	126	86	46	6	
447	407	367	327	287	247	207	167	127	87	47	7	
448	408	368	328	288	248	208	168	128	88	48	8	
449	409	369	329	289	249	209	169	129	89	49	9	
450	410	370	330	290	250	210	170	130	90	50	10	
451	411	371	331	291	251	211	171	131	91	51	11	
452	412	372	332	292	252	212	172	132	92	52	12	
453	413	373	333	293	253	213	173	133	93	53	13	
454	414	374	334	294	254	214	174	134	94	54	14	
455	415	375	335	295	255	215	175	135	95	55	15	
456	416	376	336	296	256	216	176	136	96	56	16	
457	417	377	337	297	257	217	177	137	97	57	17	
458	418	378	338	298	258	218	178	138	98	58	18	
459	419	379	339	299	259	219	179	139	99	59	19	
460	420	380	340	300	260	220	180	140	100	60	20	125 kHz
461	421	381	341	301	261	221	181	141	101	61	21	
462	422	382	342	302	262	222	182	142	102	62	22	
463	423	383	343	303	263	223	183	143	103	63	23	
464	424	384	344	304	264	224	184	144	104	64	24	
465	425	385	345	305	265	225	185	145	105	65	25	
466	426	386	346	306	266	226	186	146	106	66	26	
467	427	387	347	307	267	227	187	147	107	67	27	
468	428	388	348	308	268	228	188	148	108	68	28	
469	429	389	349	309	269	229	189	149	109	69	29	
470	430	390	350	310	270	230	190	150	110	70	30	
471	431	391	351	311	271	231	191	151	111	71	31	
472	432	392	352	312	272	232	192	152	112	72	32	
473	433	393	353	313	273	233	193	153	113	73	33	
474	434	394	354	314	274	234	194	154	114	74	34	
475	435	395	355	315	275	235	195	155	115	75	35	
476	436	396	356	316	276	236	196	156	116	76	36	
477	437	397	357	317	277	237	197	157	117	77	37	
478	438	398	358	318	278	238	198	158	118	78	38	
479	439	399	359	319	279	239	199	159	119	79	39	
480	440	400	360	320	280	240	200	160	120	80	40	250 kHz

Channels:
25 khz channel uses 4 adjacent 6.25 khz channels

Channels:
12.5 khz channel uses 2 adjacent 6.25 khz channels, but only lower 2 or upper 2 in 25 khz block

250 kHz between rows

3.0 MHz

700 MHz Wideband Channel Layout Plan – 767-773/797-803 MHz

CHANNELS	CHANNEL LABEL	USAGE PARAMETERS	FREQUENCY (lower edge)		FREQUENCY (center)	
			(base)	(mobile)	(base)	(mobile)
	(proposed)					
01 Pair 28/148	7WDAT1A	50 KHz	768.350	798.350	768.375	798.375
02 Pair 29/149	7WDAT1B	50 KHz	768.400	798.400	768.425	798.425
03 Pair 30/150	7WDAT1C	50 KHz	768.450	798.450	768.475	798.475
Pair 28-29/148-149	7WDAT1E	aggregated 100 KHz (lower)	768.350	798.350	768.400	798.400
Pair 29-30/149-150	7WDAT1F	aggregated 100 KHz (upper)	768.400	798.400	768.450	798.450
Pair 28-30/148-150	7WDAT1G	aggregated 150 KHz	768.350	798.350	768.425	798.425
04 Pair 37/157	7WDAT2A	50 KHz	768.800	798.800	768.825	798.825
05 Pair 38/158	7WDAT2B	50 KHz	768.850	798.850	768.875	798.875
06 Pair 39/159	7WDAT2C	50 KHz	768.900	798.900	768.925	798.925
Pair 37-38/157-158	7WDAT2E	aggregated 100 KHz (lower)	768.800	798.800	768.850	798.850
Pair 38-39/158-159	7WDAT2F	aggregated 100 KHz (upper)	768.850	798.850	768.900	798.900
Pair 37-39/157-159	7WDAT2G	aggregated 150 KHz	768.800	798.800	768.875	798.875
07 Pair 46/166	7WDAT3A	50 KHz - no aggregation = nationwide common	769.300	799.300	769.325	799.325
08 Pair 47/167	7WDAT3B	50 KHz - no aggregation	769.350	799.350	769.375	799.375
09 Pair 48/168	7WDAT3C	50 KHz - no aggregation = nationwide common	769.400	799.400	769.425	799.425
10 Pair 73/193	7WDAT4A	50 KHz - no aggregation = nationwide common	770.600	800.600	770.625	800.625
11 Pair 74/194	7WDAT4B	50 KHz - no aggregation	770.650	800.650	770.675	800.675
12 Pair 75/195	7WDAT4C	50 KHz - no aggregation = nationwide common	770.700	800.700	770.725	800.725
13 Pair 82/202	7WDAT5A	50 KHz	771.050	801.050	771.075	801.075
14 Pair 83/203	7WDAT5B	50 KHz	771.100	801.100	771.125	801.125
15 Pair 84/204	7WDAT5C	50 KHz	771.150	801.150	771.175	801.175
Pair 82-83/202-203	7WDAT5E	aggregated 100 KHz (lower)	771.050	801.050	771.100	801.100
Pair 83-84/203-204	7WDAT5F	aggregated 100 KHz (upper)	771.100	801.100	771.150	801.150
Pair 82-84/202-204	7WDAT5G	aggregated 150 KHz	771.050	801.050	771.125	801.125
16 Pair 91/211	7WDAT6A	50 KHz	771.500	801.500	771.525	801.525
17 Pair 92/212	7WDAT6B	50 KHz	771.550	801.550	771.575	801.575
18 Pair 93/213	7WDAT6C	50 KHz	771.600	801.600	771.625	801.625
Pair 91-92/211-212	7WDAT6E	aggregated 100 KHz (lower)	771.500	801.500	771.550	801.550
Pair 92-93/212-213	7WDAT6F	aggregated 100 KHz (upper)	771.550	801.550	771.600	801.600
Pair 91-93/202-204	7WDAT6G	aggregated 150 KHz	771.500	801.500	771.575	801.575

Note: Channels 46 & 48 and 73 & 75 are reserved
as 50 KHz Nationwide Common Channels

700 MHz Wideband Channel Layout Plan – 767-773/797-803 MHz

767 / 797 MHz (NB Channels)	150 kHz			300 kHz			450 kHz		
	1	2	3	4	5	6	7	8	9
	10	11	12	13	14	15	16	17	18
	19	20	21	22	23	24	25	26	27
	28	29	30	31	32	33	34	35	36
	37	38	39	40	41	42	43	44	45
	46	47	48	49	50	51	52	53	54
	55	56	57	58	59	60	Upper half of TV Channels 63/68		
	Lower half of TV Channels 64/69			770 / 800 MHz					
				61	62	63	64	65	66
67	68	69	70	71	72	73	74	75	
76	77	78	79	80	81	82	83	84	
85	86	87	88	89	90	91	92	93	
94	95	96	97	98	99	100	101	102	
103	104	105	106	107	108	109	110	111	
112	113	114	115	116	117	118	119	120	
						773 / 803 MHz (NB Channels)			

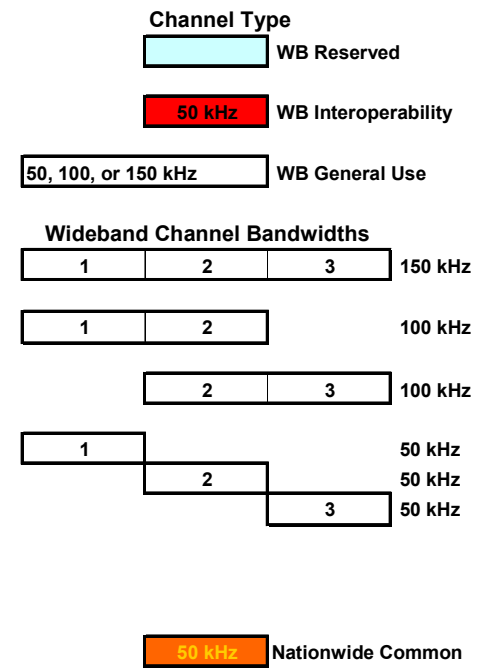

Note: Channels 46 & 48 and 73 & 75 are reserved as 50 KHz Nationwide Common Channels